



# Precision Engineering Ltd



Unit A, Crystal Works, Wormald Street, Heckmondwike, West Yorkshire WF15 7JE  
Phone +44 (0) 1924 407768 Fax +44 (0) 1924 407688 Email enquiries@dsp-eng.com

**Crimp Area:-** This is the serrated area on the crimp / sealing jaw.  
It is measured from end to end  
(In the direction of the knife slot)

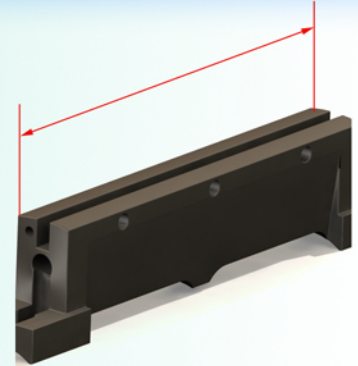

**Face Width:-** This is the width of the sealed area on the package.  
It is measured on the side of the crimp / sealing jaw  
Knife slot.

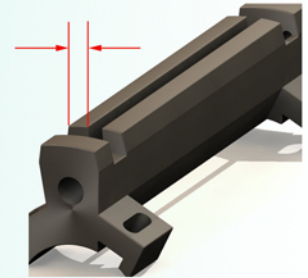

**Head Diameter:-** For Horizontal form / fill / seal wrappers.  
The distance from the centerline to centerline of the shafts. The radius on the crimps / jaws is approximately half of the head diameter.

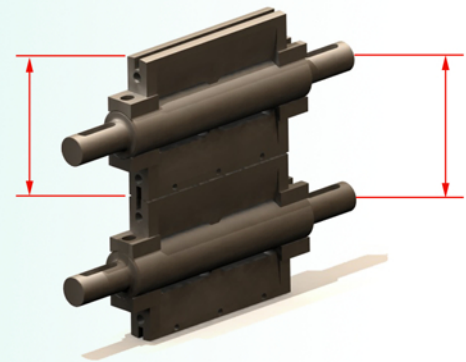

**Overall Crimper Length:-** Overall length of the crimper / jaw body

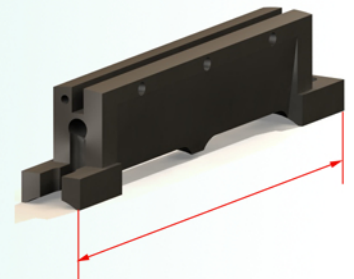

**Pitch (P):-** The width of each tooth or serration  
**Depth (D):-** The depth of each tooth or serration  
**Angle (A):-** The angle of each tooth or serration

